

## Mounting instructions for replacement guide bearings

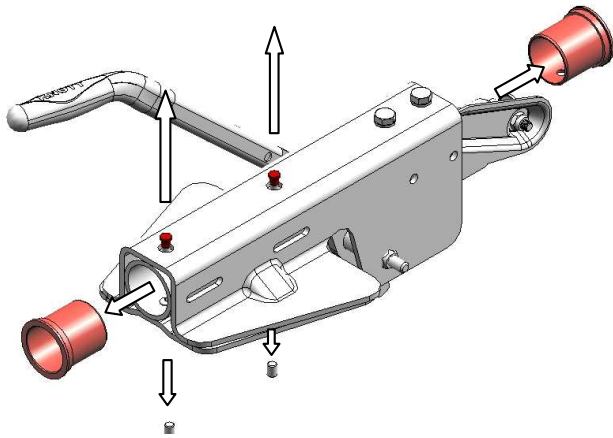

1)



Remove the grease nipple from the housing



For punched grease nipples, pull out carefully with pliers.

Remove the safety pin (plastic) and pull out the old guide bearings from the housing.

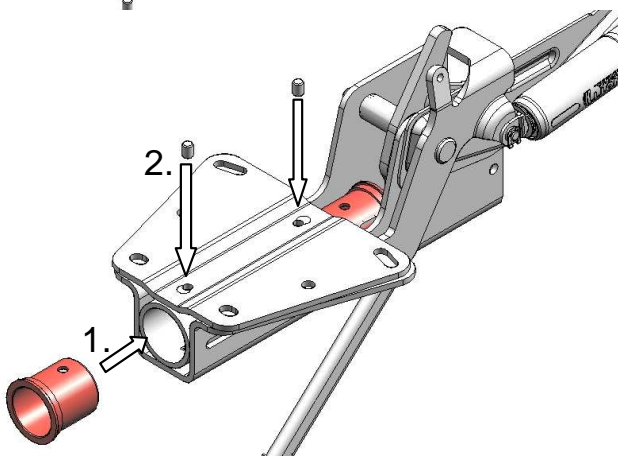

2) Press the guide bearings into the housing as far as they will go.

**Note:**

Never apply knocks to the guide bearings, as they could splinter.

3) Ream the holes for the locking pins through the guide bearings with a diameter of 9.9-0.1 and then knock in the locking pins.

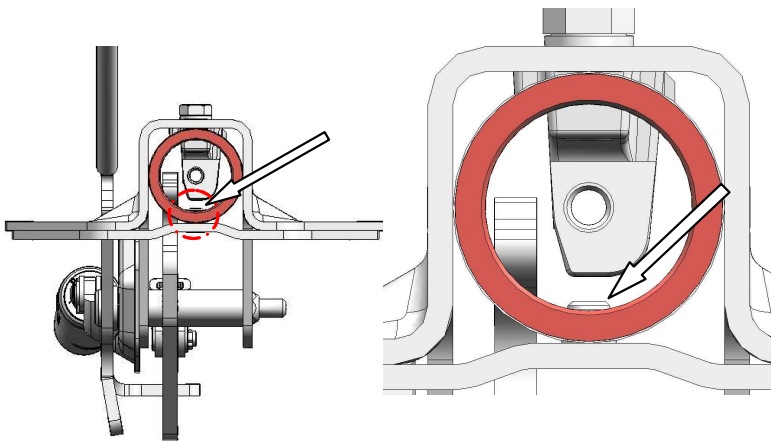

4) Carefully remove the projecting material from the locking pins. (e. g. with a half round file)

5) **With drive-in type grease nipple:**

Bore the holes through the guide bearings with  $\text{Ø}5.9-0.1$ .

Then knock the grease nipple back in.

**With screw-type grease nipple:**

Bore the holes through the guide bearings with  $\text{Ø}5.0-0.2$ . Then screw the grease nipple back in.



Lubricate the draw tube lightly and assemble it in the housing.  
Lubricate sufficiently through the grease nipple with commercial lubricating grease (e. g. lithium soap grease).

